

Motor enabled Motor disabled

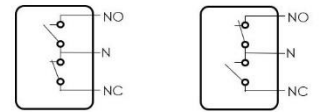

Refer to the shutdown relays connection examples.

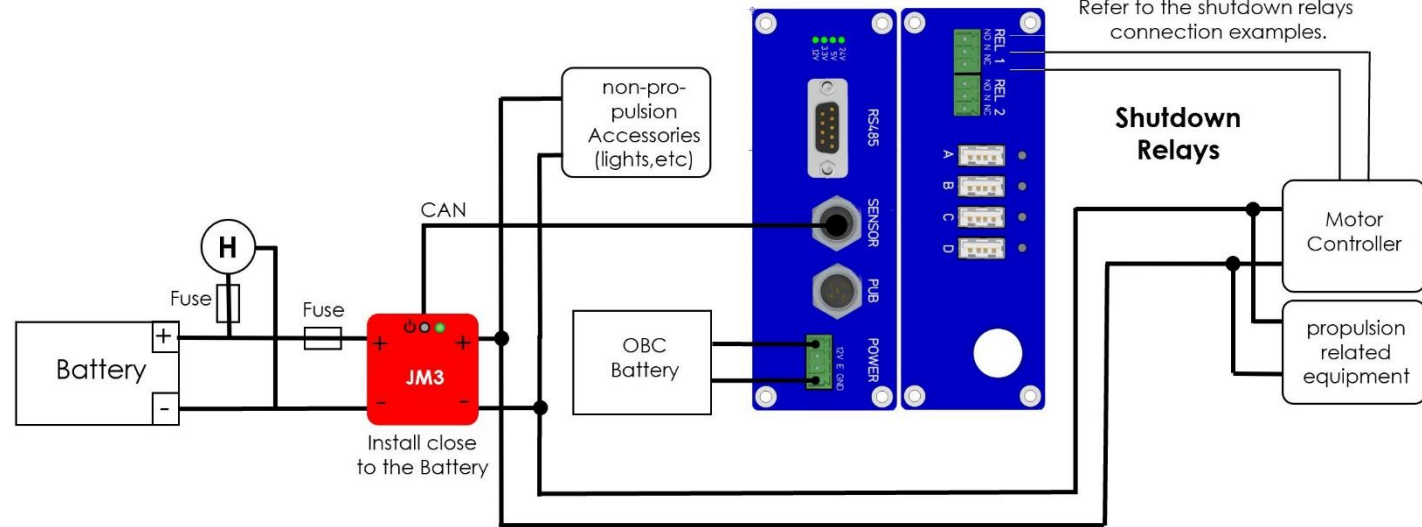

Self Inspection Checklist

Do not come to Telemetry Inspection until all boxes checked off

- OBC-Pod** mounted correctly
 - OBC Pod unobstructed field of view of 90° to all sides
 - OBC Pod < 20° off horizon (pitch & roll)
 - OBC Pod in driving direction
 - OBC Pod 10cm of cable lift available (a Fist)
- OBC Backbone** mounted correctly
- Battery** mounted correctly
 - removable to the side or up, no tapes
 - > 60% of charge
- Sensors** mounted correctly
 - JM3 2x **green light** (Status OK, Battery Charged)
 - JM3 Buttons accessible, LEDs visible
- Cables** mounted correctly
 - No wide loops in cables
 - Cables mounted securely
 - Strain reliefs applied
 - Connectors fastened (Check the «click» at the end)
- No direct electrical connection of OBC to car body or chassis**
- OBC** working properly
 - LEDs after 1min = **Green Off Blue Yellow**
- Shutdown Relay** working properly
 - Start engine (if not yet running)
 - Simulate relay with supplied electronic switch
 - Engine stops

Team: Checklist Complete

Inspector

Date	Name	Signature